



Caproni



MOTOR-PUMPS UNIT

MOTOR - PUMP

DCM 0.7/8.0/22-01-V - 10A3.15X001G

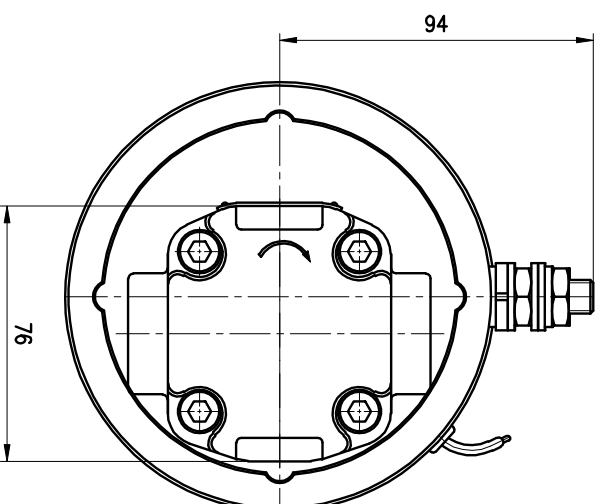
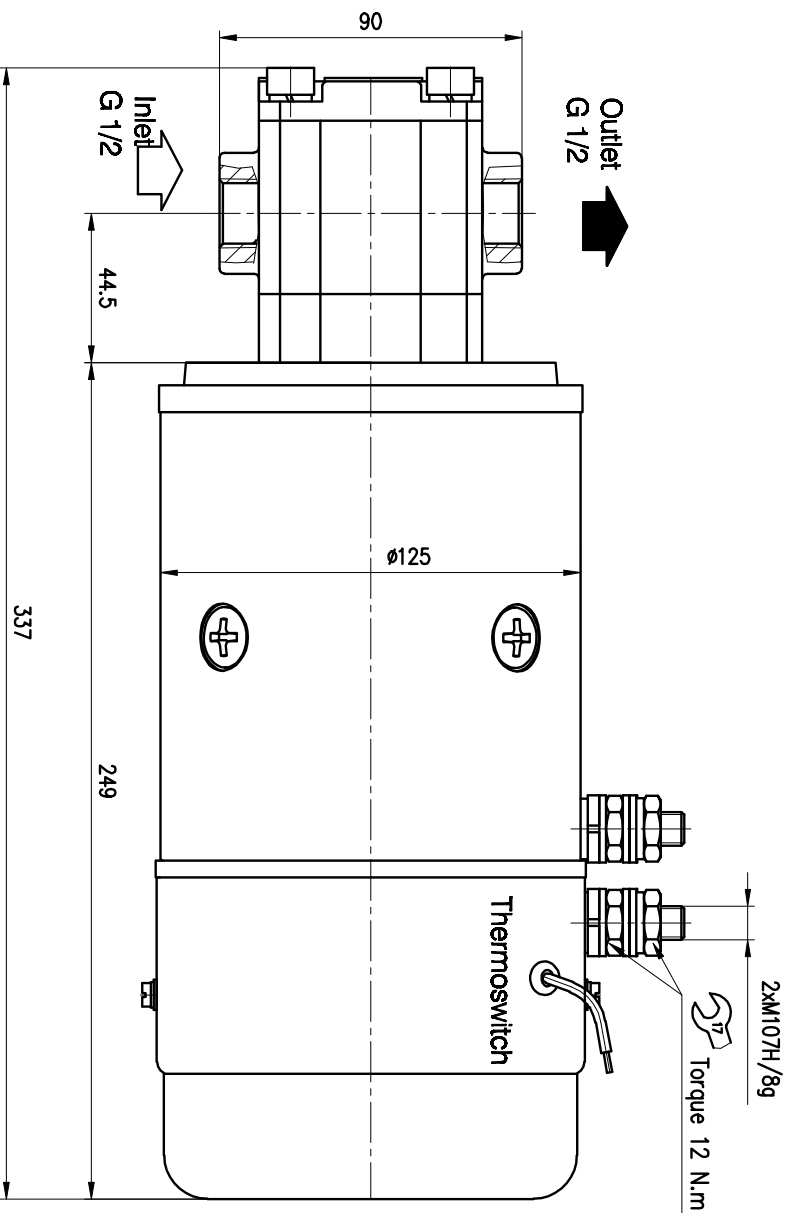

MOTOR

Rated Power 0.7 kW
 Supply Voltage 80 V
 Rated speed 2200 rpm
 Operation mode S2 = 60 min
 Excitation Compound

PUMP

Displacement 3.15 cc
 Max pressure 50 bar
 Flow ~6.6 L/min

Weight ~ 12 kg

Connection Diagram

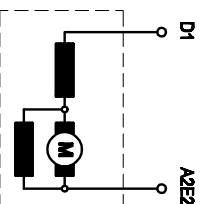

JOINT-STOCK COMPANY
caproni
 HYDRAULIC COMPONENTS AND SYSTEMS

6100 Kazanek, BULGARIA, 45, General Sotirov Str.
 Tel: +359 /431/62 228; 6132
 Fax: +359 /431/ 62 230; +359 /431/ 63 134
 E-mail: caproni@caproni.bg; WEB: www.caproni.bg

MOTOR - PUMP
DCM 3/2.4/35-01-V - 10A3.15X001G

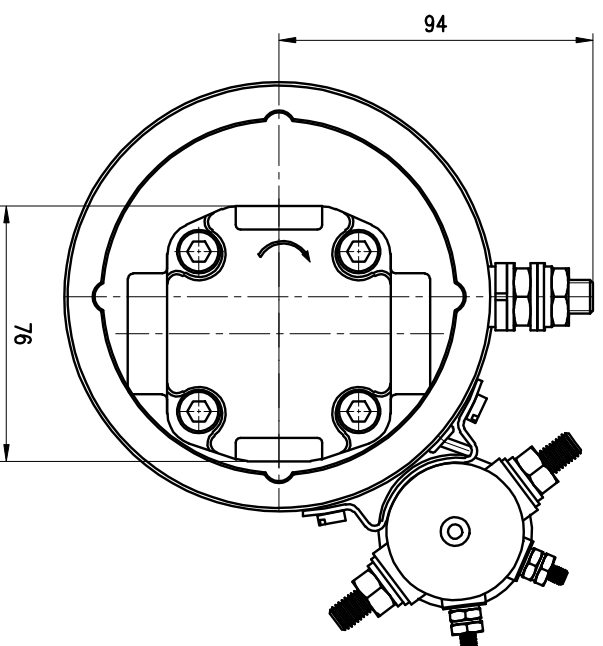
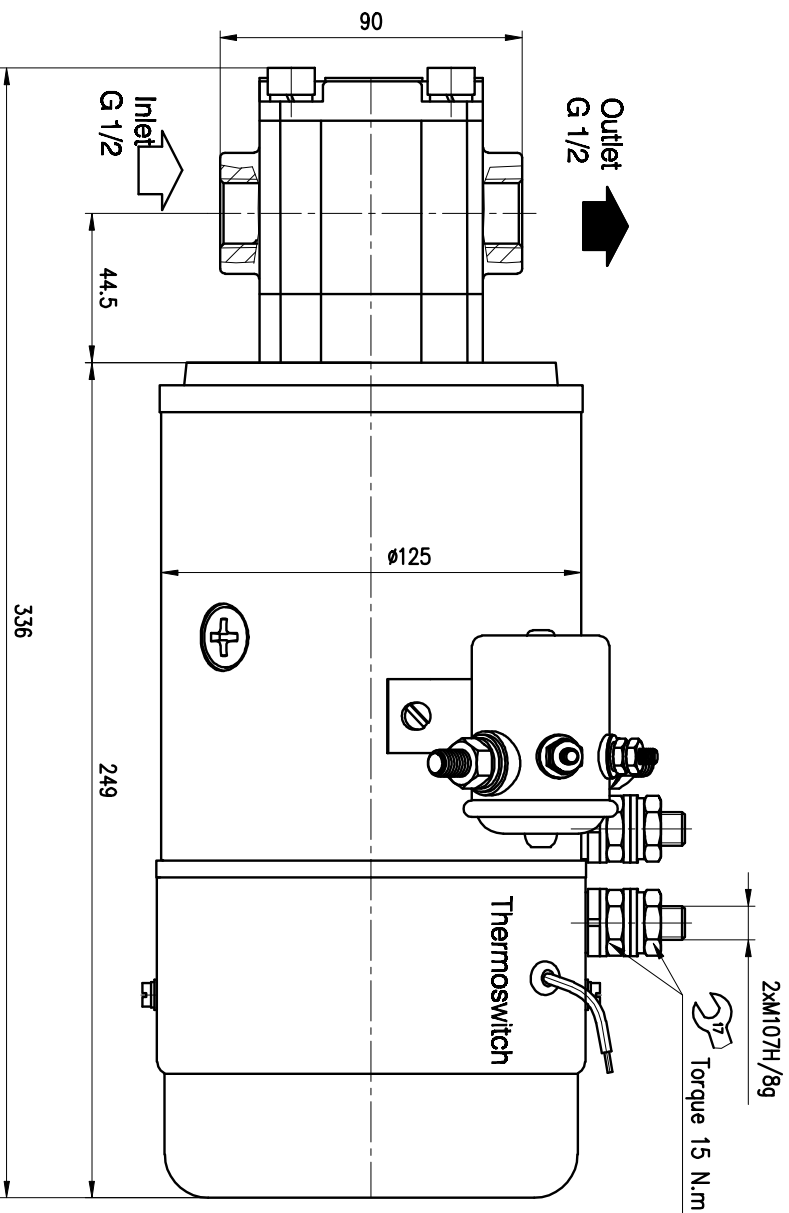

MOTOR

DCM 3/2.4/35-01-V
 Rated Power 3 kW
 Supply Voltage 24 V
 Operation mode S2 = 10 min
 Rated speed 3500 rpm

PUMP

10A3.15X001G
 Max pressure 150 bar
 Flow 10.5 L/min

Weight ~ 12 kg



JOINT-STOCK COMPANY
caproni

HYDRAULIC COMPONENTS AND SYSTEMS

6100 Kazanek, BULGARIA, 45, General Sotirov Str.
 Tel: +359 /431/62 228; 6231
 Fax: +359 /431/ 62 230; +359 /431/ 63 134
 E-mail: caproni@caproni.bg; WEB: http://www.caproni.bg



caproni

BULGARIA JOINT-STOCK COMPANY

BULGARIA, 6100 KAZANLAK, 45 ST OLETOV STR.

TEL.: +359/431/62 229, +359/431/61 32,

FAX: +359/431/62 230, +359/431/63 134

E-MAIL: CAPRONI@CAPRONI.BG, WEB: HTTP://WWW.CAPRONI.BG